

GFB Mach 2

Part #T9125



+61 2 9534 0099

sales@gfb.com.au

www.gfb.com.au

facebook.com/GFBturbo

instagram.com/gofastbits

GFB
GO FAST BITS

TURBO MANAGEMENT SYSTEMS



PERFORMANCE WITHOUT COMPROMISE

Installation

T9125 is suitable for custom hose-mount installations using 25mm/1" I.D. inlet and outlet hoses, and is also a suitable replacement for factory-fitted plastic Bosch valves.

- 1) Locate and remove the existing factory diverter valve from the hoses, or in a custom setup weld a suitable 25mm/1" hose barb onto the intercooler piping and turbo intake pipe.

- 2) **CHECK THE ORIENTATION BEFORE INSTALLING THE MACH 2!**

Typically, most factory-fitted 25mm Bosch diverter valves are oriented such that boost pressure enters the side, and dumps through the base fitting. The GFB Mach 2 **MUST** be installed in the opposite orientation, so that boost pressure enters the base and dumps through the side. Please check the hoses to make sure you know which one is boost pressure, and which one is the recirc path.

- 3) Install the Mach 2 valve, connecting the base fitting to the boost pressure supply and the side outlet to the turbo intake. Secure both hoses with a hose clamp.
- 5) Connect the vacuum hose to the nipple on the top of the Mach 2. Try to avoid attaching any other hoses and t-pieces to the vacuum hose and keep it as short as possible, as this will ensure rapid response from your GFB valve. **DO NOT CONNECT THE VACUUM HOSE TO BOOST CONTROL, FUEL PRESSURE REGULATOR OR BRAKE BOOSTER HOSES.**
- 5) Note that Audi/VW 1.8t engines with drive-by-wire throttle use a solenoid valve and vacuum tank system inline with the BOV/diverter vacuum hose. The solenoid is known as the "N249" valve. This system is ECU controlled and has very long and restrictive vacuum hoses. Sometimes, bypassing the N249 valve with a hose directly from the manifold to the BOV can speed up the valve's response time and smooth boost delivery.
- 7) If necessary, the cap can be rotated so the vacuum nipple points in a different direction. Simply unscrew the 4 cap screws and rotate the cap to a new position (there are screw holes every 45 degrees) and reinstall the screws.

Adjusting the Spring Pre-Load

PLEASE NOTE!

The spring pre-load **DOES NOT need to be adjusted for different boost pressures.** The Mach 2 will stay shut under full throttle conditions *regardless of boost pressure* or spring pre-load.

Rather, the spring pre-load affects how easily the valve opens when you lift the throttle, and how long it stays open when it vents.

The screw in the centre of the head is the spring adjustment. Use the supplied 5mm hex key to make adjustments.

The softest spring setting is achieved when the adjustment screw is 3mm above the head of the valve as shown to the right. Do not set the screw more than 3mm above the head.

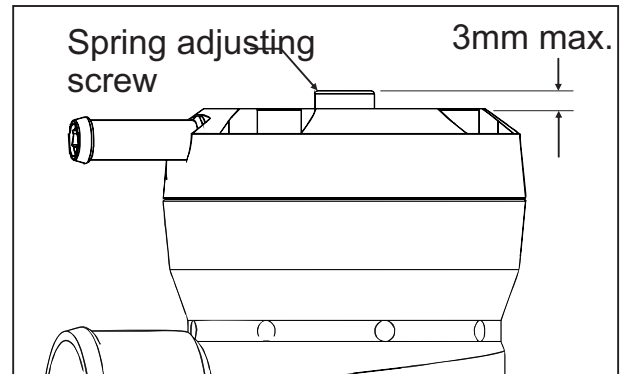

Unlike an atmosphere-venting BOV, the spring pre-load on the Mach 2 does not need to be adjusted to prevent stalling or backfiring, since all of the vented air is recirculated in the same way as the OEM bypass valve.

It is therefore possible to use the Mach 2 straight out of the box without any spring pre-load adjustments, however you can use the adjustment to fine-tune throttle response. Generally speaking, the hardest spring pre-load you can run without causing compressor surge (fluttering sound when lifting off the throttle) is ideal.

To set the spring pre-load for maximum throttle response:

- Set the spring to the hardest setting (adjust the screw all the way down).
- Start the car and drive it until it is warm, and make sure the A/C is off.
- Accelerate moderately in a high gear to about 3000RPM and then ease off the accelerator, keeping the clutch engaged - these are the conditions most likely to cause compressor surge. If you hear a fluttering sound as you lift off, turn the adjustment screw in the “-” direction one turn at a time until the noise disappears. This is now the ideal setting for best throttle response.

Note that all cars have a different threshold for compressor surge (especially when the car is modified with bigger turbo/intercooler etc) so it is possible that you may be able to leave the valve in the hardest setting without hearing surge.

Don't be afraid to experiment with the spring pre-load adjustment, you can't cause any damage by doing so, and getting the setting right to suit your car can help to optimise throttle response.

Alternative Adaptors Available

Ba	Recirc (outlet) adaptors:
se (inlet) adaptors:	5220 – 20mm
5320 – 20mm hose base	5227 – 27mm
5330 – 30mm hose base	5230 – 30mm
5333 – 33mm hose base	5233 – 33mm
5335 – 35mm hose/1" pipe mount base	5238 – 38mm
5338 – 38mm (1.5") pipe mount base	
5339 – 38mm hose base	
5350 – HKS style mounting flange	

Maintenance

GFB blow-off valves are designed to be as maintenance-free as possible. In most cars the small amount of crankcase and rocker-cover oil vapor that is directed into the intake system is enough to keep the piston well lubricated indefinitely.

However, if you notice the sound of the valve changing over time (e.g. slow response time, intermittent operation), or if you can see that the piston is not moving smoothly, it may require a clean and re-lube.

Cleaning Procedure: Remove the four screws holding on the cap, taking care as the spring will try to push the cap off as the last screw is removed. Remove the spring and the brass piston, and wipe any grime from the inside of the valve and the piston with a rag. Apply normal engine oil to the piston and the inside of the bore, and re-assemble.

Warranty

WARNING:

GFB recommends that only qualified motor engineers fit this product. GFB products are engineered for best performance, however incorrect use or modification may cause damage to or reduce the longevity of the engine/drive-train components.

GFB LIFETIME WARRANTY:

Our commitment to quality means that when we put our name to something, we are also staking our reputation on it. That's why we back our products with the best warranty in the business!

You should expect a lifetime of use from a well-engineered product, so if your GFB product fails as a result of defective materials or faulty workmanship whilst you remain the original owner, we will repair or replace it (limited only to the repair or replacement of GFB products provided they are used as intended and in accordance with all appropriate warnings and limitations. No other warranty is expressed or implied).

If a fault occurs as a result of usage outside of the terms of the warranty, or you are not the original owner, fear not, we can still help you. You should never need to throw a GFB product away, as spare parts are available and won't cost the earth.

TECH SUPPORT:

We want you to get the best advice, first time. That's why our engineers are available to answer any technical questions you may have.

Head to www.gfb.com.au/contact-us to get in touch.